

PAD XTRAIL

INSTRUCTION FOR PAD REPLACEMENT

VENICE XTRAIL

- 1) Turn the stirrup upside down and leave it in this position until the end of the replacement procedure.
- 2) Unscrew the 6 screws placed under the tread using the specific wrench included in the package.
- 3) Remove the pad and the shock absorbers from their housing.

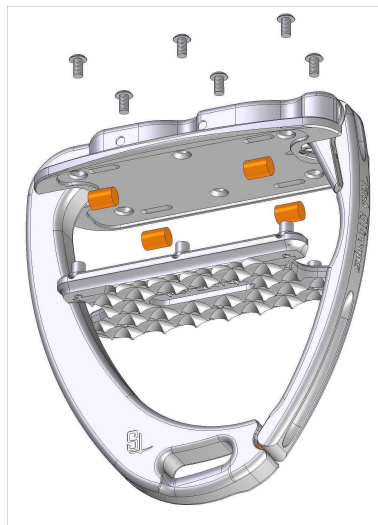

- 4) Take the new pad and insert the 4 new shock absorbers in their specific housings.

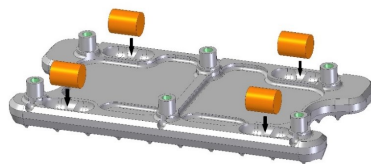

- 5) Keeping the stirrup upside down, insert the new pad in its specific housing.
- 6) Take 2 new screws and fix them in the 2 middle holes using the specific wrench.
- 7) Take 4 new screws and fix them in the remaining holes always using the specific wrench.

Make sure all screws are tight